

PARTS LIST			
ITEM	PART NO	QTY	DESCRIPTION
1	0925-002	1	CC925 AXIAL FAN CASING- 45kW
2	0925-003	1	CC925 AXIAL FAN GUIDE VANE WELDED ASSY
3	0925-005	1	CC925 INLET CONE
4	0925-006	4	CC925 FAN MOUNTING FOOT
5	0925-011	1	CC925 FAN VENT TUBE ADAPTOR TO 915mm DUCT
6	0925-025	2	CC925 AXIAL FAN SILENCER OUTER CASE- 1650L
7	0925-503	1	CC925 AXIAL FAN- 45kW- MOTOR & GUIDE VANE STAGE
8	CC925-IMPELLER	1	CC925 IMPELLER
9	MOTOR-TERM-BOX-TECO-D225	1	TERMINAL BOX- SUIT TECO D225 FRAME
10	TECO-FOOT-45KW-2P-225MA	1	TECO 45kW 2POLE 225M FRAME 1000 VOLT MOTOR

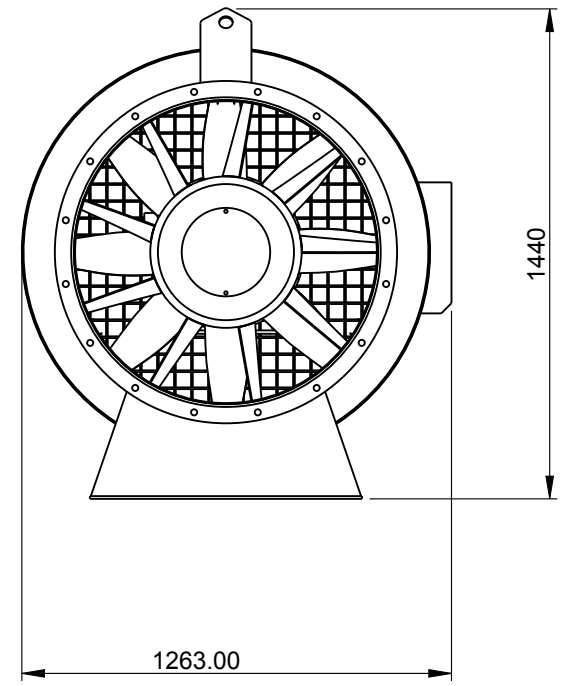

- NOTES**
- ALL MOTOR HOLD DOWN BOLTS, NUTS AND WASHERS TO COMPLY WITH AS1110 CLASS 8.8 ZINC PLATED. CONE LOCKING NUTS TO BE USED. ENSURE BOLTS ARE TIGHTENED TO CORRECT TORQUE
 - ALL FLANGE BOLTS, NUTS AND WASHERS TO COMPLY WITH AS1111 CLASS 4.6 ZINC PLATED U.N.O

MASS:	SURFACE AREA:	VOLUME:	PROJECTION: 	COPYRIGHT This drawing including the principles of design is the property of and is submitted by CLEMFCORP (WA) Pty Ltd with the agreement that it is not to be reproduced, copied or loaned in part or whole it is not to be used in any manner that may constitute a detriment directly or indirectly to CLEMFCORP (WA) Pty Ltd. Acceptance of this drawing will be construed as an agreement to the above.	 CLEMFCORP (WA) Pty Ltd trading as Clemcorp Australia ABN: 54 115 959 683 PO Box 4249 Alexander Heights 6064 Western Australia Ph: (08) 9406 3000 Fax: (08) 9406 3001 www.clemcorp.com.au
MATERIAL:			TOLERANCE: U.N.O		
ALL DIMENSIONS IN MM U.N.O DRAFTING STANDARD AS1100 DO NOT SCALE			$X^{\circ} \pm 0.5^{\circ}$ $X \pm 1$ $X.X \pm 0.2$ $X.XX \pm 0.02$ $>1000 \text{ mm} \pm 2$	CC925 AXIAL FAN- 45kW ASSEMBLY W/ SILENCERS	
Drawn		L. MATTABONI	18-08-10	Drawing Number	
Checked		.	Scale	0925-501	
Approved		.	NTS	SHEET 1 OF 1	

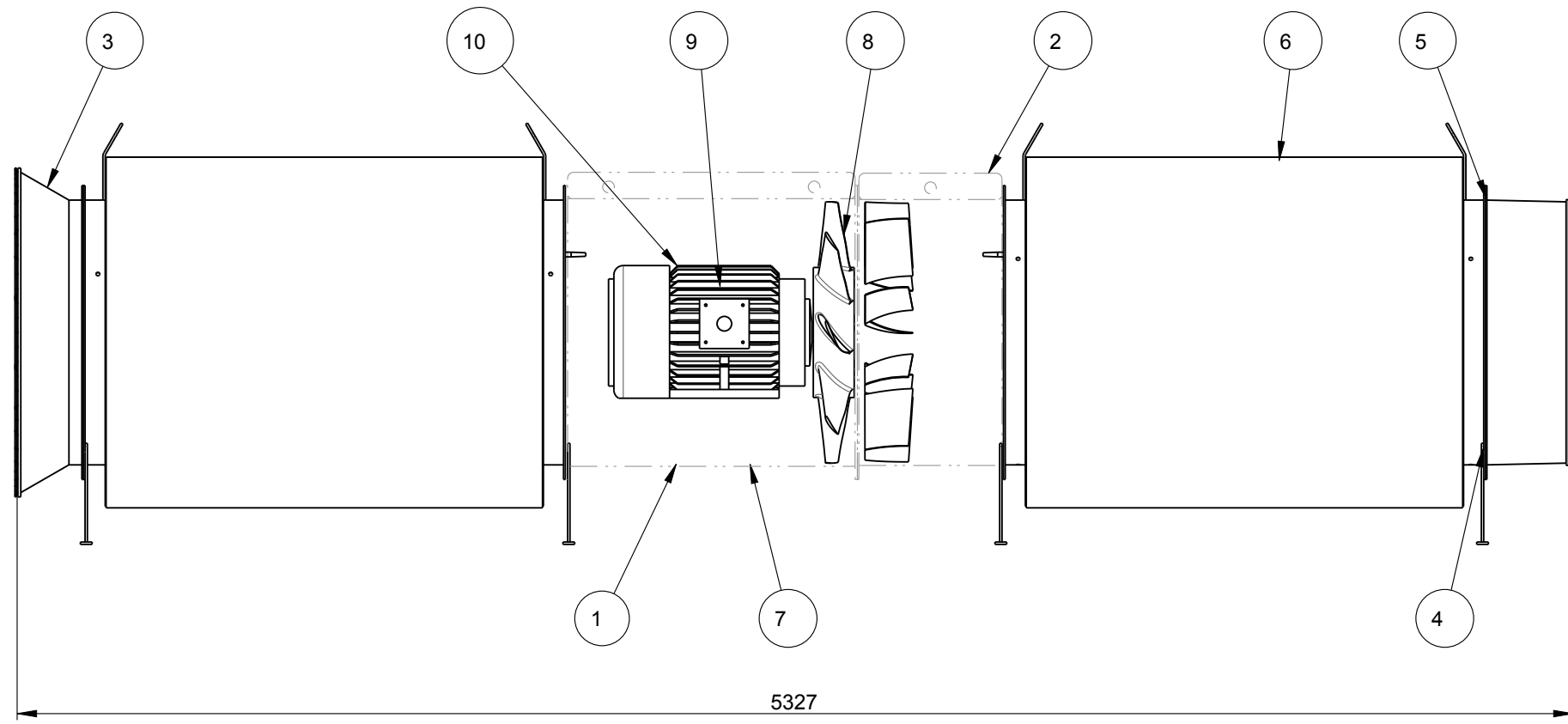