

ISO-VIEW  
SCALE 1:40

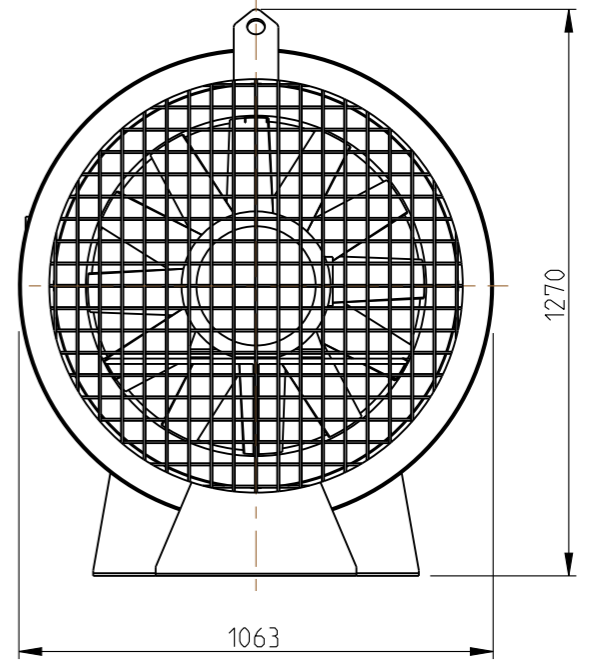
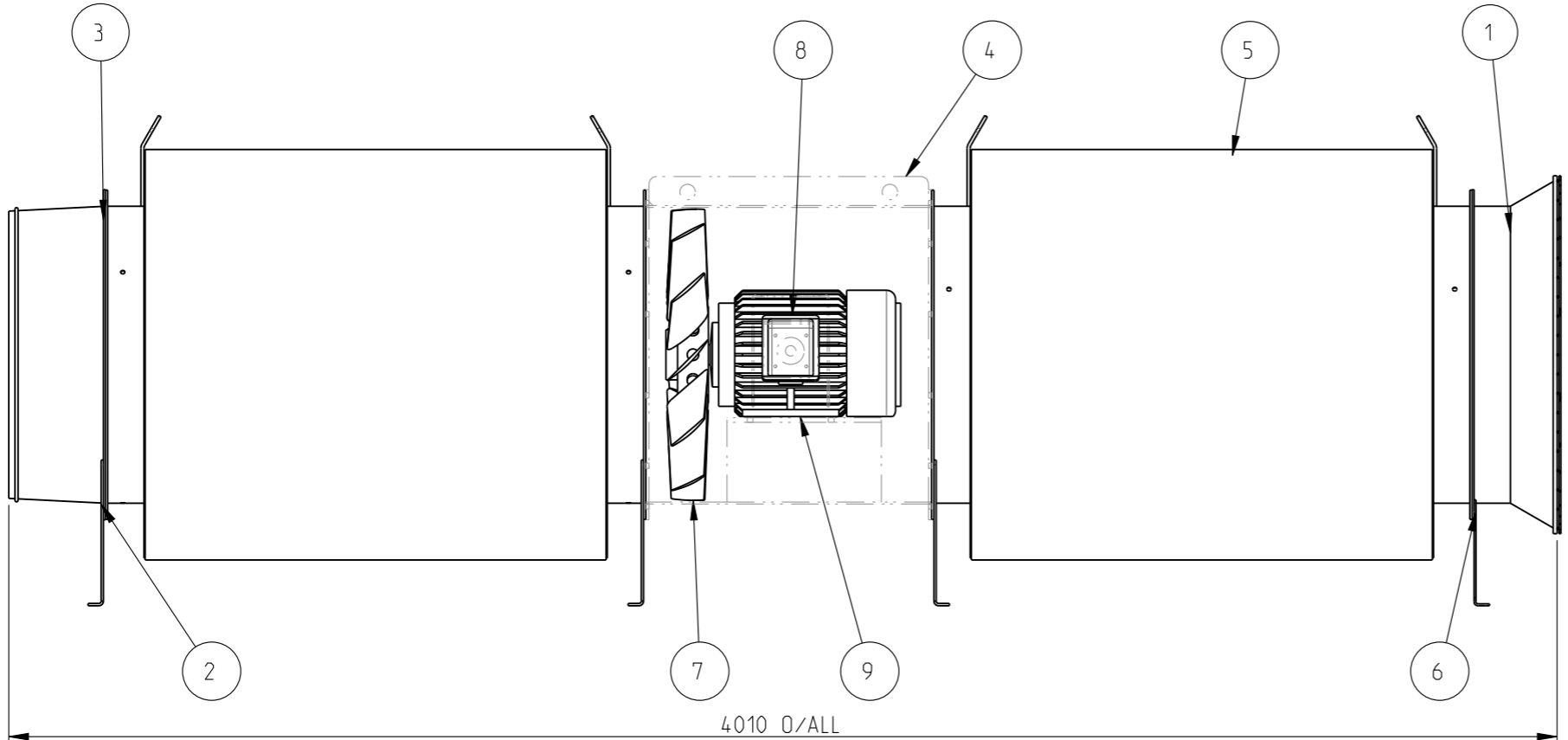

PARTS LIST				
ITEM	PART NO	QTY	DESCRIPTION	CHECKED
1	0762-001	1	CC762 INLET CONE	
2	0762-004	3	MOUNTING FOOT- CC762 FAN	
3	0762-005	1	CC762 FAN VENT TUBE ADAPTOR TO 760mm DUCT	
4	0762-010	1	CC762 AXIAL FAN CASING- FOOT MTD 11/15kW	
5	0762-020	2	CC762 AXIAL FAN SILENCER OUTER CASE- 1400L	
6	0762-026	1	TRANSPORT FOOT- CC762 SILENCER	
7	0762-028	1	CC762 15KW IMPELLER- TITAN 300 SERIES	
8	MOTOR-TERM-BOX-TECO-132S-180L	1	TERMINAL BOX- SUIT TECO 132-180 FRAMES	
9	TECO-FOOT-15KW -2P-160M	1	TECO 15kW 2POLE 160M FRAME 1000 VOLT MOTOR	

- NOTES
1. ALL MOTOR HOLD DOWN BOLTS, NUTS AND WASHERS TO COMPLY WITH AS1110 CLASS 8.8 ZINC PLATED. CONE LOCKING NUTS TO BE USED. ENSURE BOLTS ARE TIGHTENED TO CORRECT TORQUE
  2. ALL FLANGE BOLTS, NUTS AND WASHERS TO COMPLY WITH AS1111 CLASS 4.6 ZINC PLATED U.N.O

MASS: 708.7 kg	SURFACE AREA: 86.54 m <sup>2</sup>	VOLUME: 0.112 m <sup>3</sup>	PROJECTION: 	COPYRIGHT		CLEM CORP (WA) Pty Ltd trading as <b>Clemcorp Australia</b> ABN: 54 115 959 683 PO Box 4249 Alexander Heights 6064 Western Australia Ph: (08) 9406 3000 Fax: (08) 9406 3001 www.clemcorp.com.au
MATERIAL:			TOLERANCE: U.N.O	This drawing including the principles of design is the property of and is submitted by CLEM CORP (WA) Pty Ltd with the agreement that it is not to be reproduced, copied or loaned in part or whole if it is not to be used in any manner that may constitute a detriment directly or indirectly to CLEM CORP (WA) Pty Ltd. Acceptance of this drawing will be construed as an agreement to the above.		
ALL DIMENSIONS IN MM U.N.O DRAFTING STANDARD AS1100 DO NOT SCALE			X* ± 0.5° X ± 1 X.X ± 0.2 X.XX ± 0.02 >1000 mm ± 2	<b>CC762 AXIAL FAN- 15KW- GENERAL ARRANGEMENT</b>		Drawing Number <b>0762-106</b>
DATE	DESCRIPTION	REV	BY	Scale NTS	SHEET 1 OF 1	Rev. 0

