

PARTS LIST				
ITEM	PART NO	QTY	DESCRIPTION	CHECKED
1	0020-001	1	CC20 AIR FAN CASING WELDED ASSEMBLY	
2	0020-004	1	CC20 CAST IMPELLER	
3	0020-009	1	CC20 BLANKING PLATE	
4	0020-017	1	CC20 WASHER SHAFT MACHINED COMPONENT	
5	0020-028	1	CC20 MESH SCREEN- WELDED ASSEMBLY	
6	0020-524	1	CC20 MOTOR AND SHAFT COMPLETE ASSEMBLY	
7	FWM-8	8	M8 FLAT WASHER- STEEL	
8	HBM-825	4	HEX BOLT M8x1.25 X 25 LONG GRADE 8.8 ZINC PLATED	
9	HNM8-NUT	4	HEX NUT M8x1.25- GRADE 8.8 ZINC PLATED	
10	MP-195	1	3/4" UNF NYLOC NUT - ZINC PLATED	

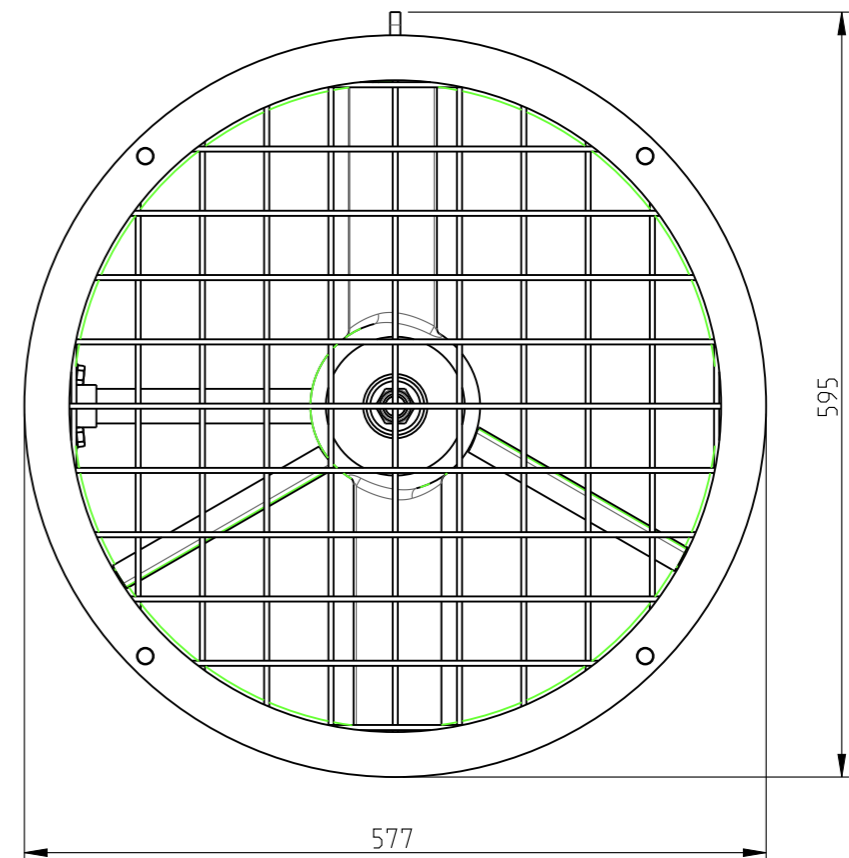
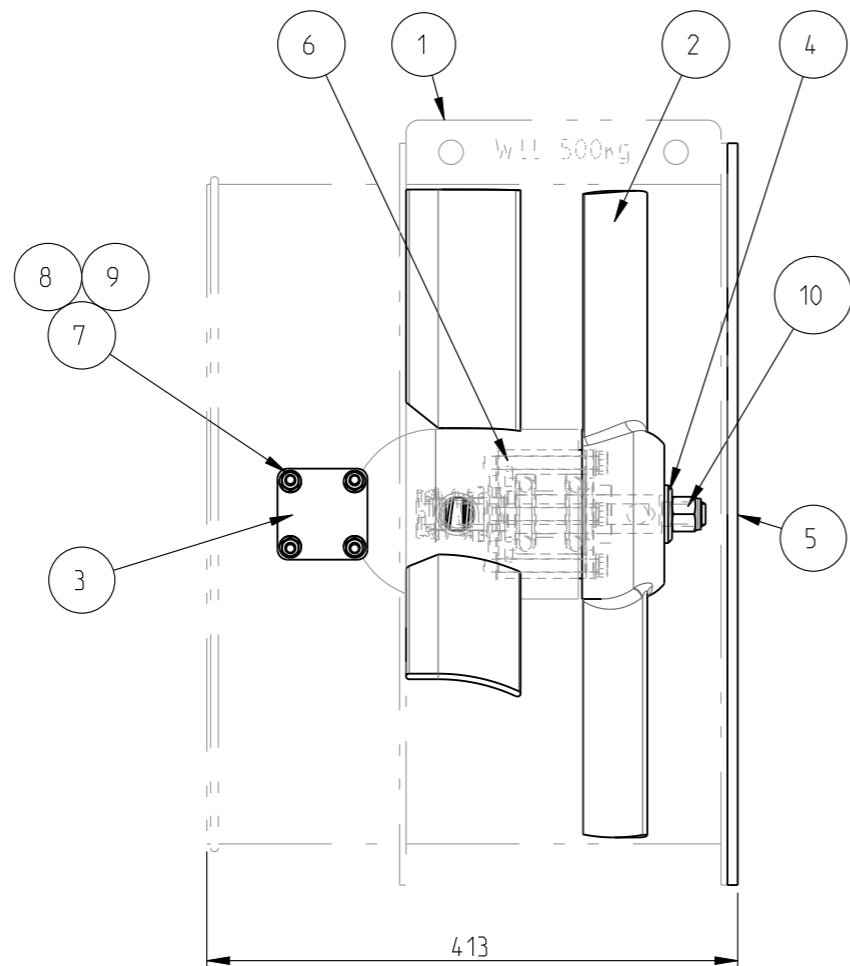

NOTES

1. ALL MOTOR HOLD DOWN BOLTS, NUTS AND WASHERS TO COMPLY WITH AS1110 CLASS 8.8 ZINC PLATED. ENSURE BOLTS ARE TIGHTENED TO CORRECT TORQUE
2. ALL FLANGE BOLTS, NUTS AND WASHERS TO COMPLY WITH AS1111 CLASS 4.6 ZINC PLATED U.N.O

MASS: 40.3 kg	SURFACE AREA: 2.48 m ²	VOLUME: 0.006 m ³	PROJECTION: 	COPYRIGHT		CLEM CORP (WA) Pty Ltd trading as Clemcorp Australia ABN: 54 115 959 683 PO Box 4249 Alexander Heights 6064 Western Australia Ph: (08) 9406 3000 Fax: (08) 9406 3001 www.clemcorp.com.au
MATERIAL: -			TOLERANCE: U.N.O	This drawing including the principles of design is the property of and is submitted by CLEM CORP (WA) Pty Ltd with the agreement that it is not to be reproduced, copied or loaned in part or whole if it is not to be used in any manner that may constitute a detriment directly or indirectly to CLEM CORP (WA) Pty Ltd. Acceptance of this drawing will be construed as an agreement to the above.		
ALL DIMENSIONS IN MM U.N.O DRAFTING STANDARD AS1100 DO NOT SCALE				X° ± 0.5° X ± 1 X.X ± 0.2 X.XX ± 0.02 >1000 mm ± 2		CC20 AIR FAN- COMPLETE ASSEMBLY
10-04-17	NEW FLANGE UPDATE & INLET SCREEN	2	A S WESTON	Drawn	A S WESTON	10-04-17
DATE	DESCRIPTION	REV	BY	Checked	.	Scale
				Approved	.	NTS
				Drawing Number		Rev.
				0020-506		2
				SHEET 1 OF 1		Design

