

PARTS LIST

ITEM	PART NO	REV	DESCRIPTION	QTY	MASS (ea) kg
1	1400-001	12	CC1400 AXIAL FAN CASING- INLET 90/110kW	1	519.4
2	1400-004	3	CC1400 INLET CONE	1	89.4
3	1400-007	3	MOUNTING FOOT- CC1400 FAN- STD	2	26.6
4	1400-025	7	CC1400 AXIAL FAN GUIDE VANE WELDED ASSY	1	175.6
5	1400-070	2	CC1400 PLASTIC VENT TUBE ADAPTER TO 1400mm DUCT	1	18.4
6	1400-071	4	TRANSPORT FOOT- CC1400 SILENCER	2	4.2
7	1400-128	3	CC1400Mk4- 27deg 80mm BORE 132kW - IMPELLER MACHINING	1	143.6
8	1400-280	6	CC1400 AXIAL FAN SILENCER- RIVETED ASSEMBLY	2	181.9
9	EM-145	3	TECO 132kW 4P 280MC (CUSTOM FRAME 280L INTERNAL) 1000 VOLT MOTOR	1	940.0
10	MOTOR-TERM-BOX-TECO-D280-315	3	TERMINAL BOX- SUIT TECO D280-315 FRAME	1	35.0

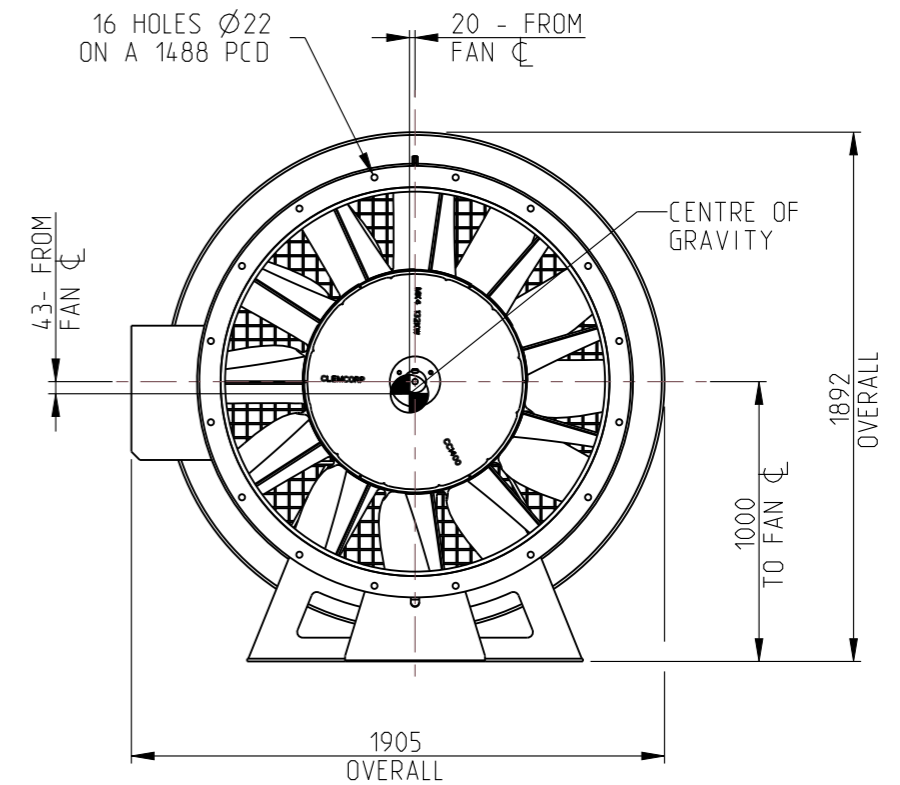
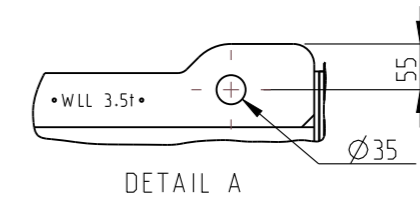
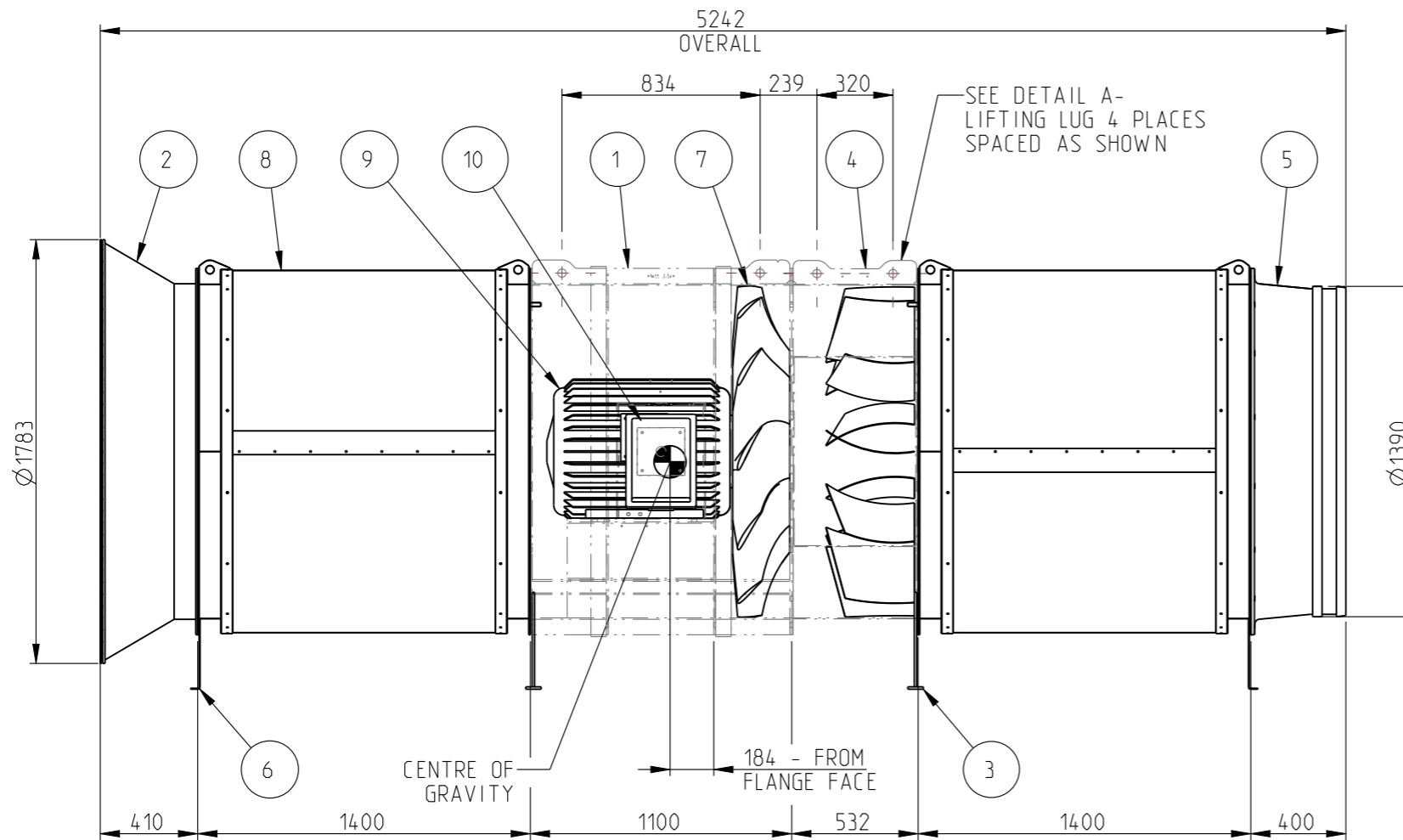

ASSEMBLY NOTES

- ALL MOTOR HOLD DOWN BOLTS, NUTS AND WASHERS TO COMPLY WITH AS1110 CLASS 8.8 ZINC PLATED. CONE LOCKING NUTS TO BE USED. ENSURE BOLTS ARE TIGHTENED TO CORRECT TORQUE
- ALL FLANGE BOLTS, NUTS AND WASHERS TO COMPLY WITH AS1111 CLASS 4.6 ZINC PLATED U.N.O

MASS: 2347.0 kg	SURFACE AREA: 114.48 m ²	VOLUME: 0.980 m ³	PROJECTION: 	COPYRIGHT		CLEM CORP (WA) Pty Ltd trading as Clemcorp Australia ABN: 54 115 959 683 PO Box 4249 Alexander Heights 6064 Western Australia Ph: (08) 9406 3000 Fax: (08) 9406 3001 www.clemcorp.com.au	
MATERIAL: -			ALL DIMENSIONS IN MM AT 20°C TEMP UNO DRAFTING STANDARD AS1100.101 & AS1100.201 DO NOT SCALE		This drawing including the principles of design is the property of and is submitted by CLEM CORP (WA) Pty Ltd with the agreement that it is not to be reproduced, copied or loaned in part or whole if it is not to be used in any manner that may constitute a detriment directly or indirectly to CLEM CORP (WA) Pty Ltd. Acceptance of this drawing will be construed as an agreement to the above.		
19-01-23	DRAWING FORMAT UPDATED	5	L PADGETT	Drawn	A S WESTON	19-01-23	Drawing Number
DATE	DESCRIPTION	REV	BY	Checked	.	Scale	1400-581
				Approved	.	NTS	SHEET 1 OF 1 Design

