

### PARTS LIST

ITEM	PART NO	QTY	DESCRIPTION	MASS (kg)
1	1254-002	1	CC1254 GUIDE VANE- GV2 WELDED ASSY	256.6
2	1254-015	1	CC1254 MK3 AXIAL FAN CASING- 55kW OUTLET	307.5
3	1254-026	1	CC1254 INLET CONE	52.8
4	1254-035	1	CC1254 PLASTIC VENT TUBE ADAPTER TO 1220mm DUCT	17.5
5	1254-044	2	MOUNTING FOOT- CC1254 FAN- STD	34.2
6	1254-052	2	TRANSPORT FOOT- CC1254 SILENCER (STD & MIM SPEC)	7.6
7	1254-062	1	CC1254 MK3- 24.5deg 70mm BORE 75kW - OUTLET IMPELLER MACHINING	69.0
8	1254-146	2	CC1254 AXIAL FAN SILENCER- RIVETED ASSEMBLY	310.9
9	EM-029	1	TECO 75kW 4POLE 250MC FRAME 1000 VOLT MOTOR	570.0
10	MOTOR-TERM-BOX-TECO-D250	1	TERMINAL BOX- SUIT TECO D250 FRAME	26.0

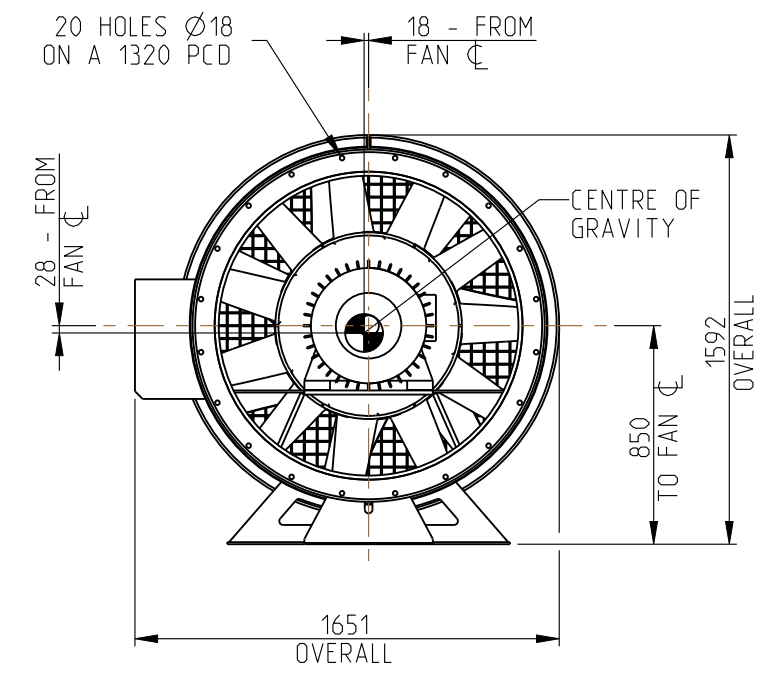
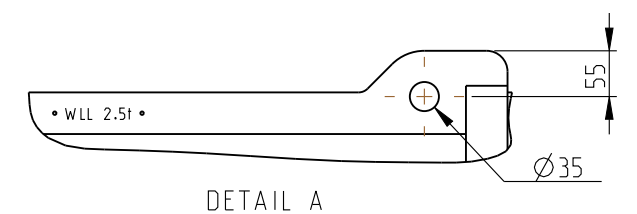
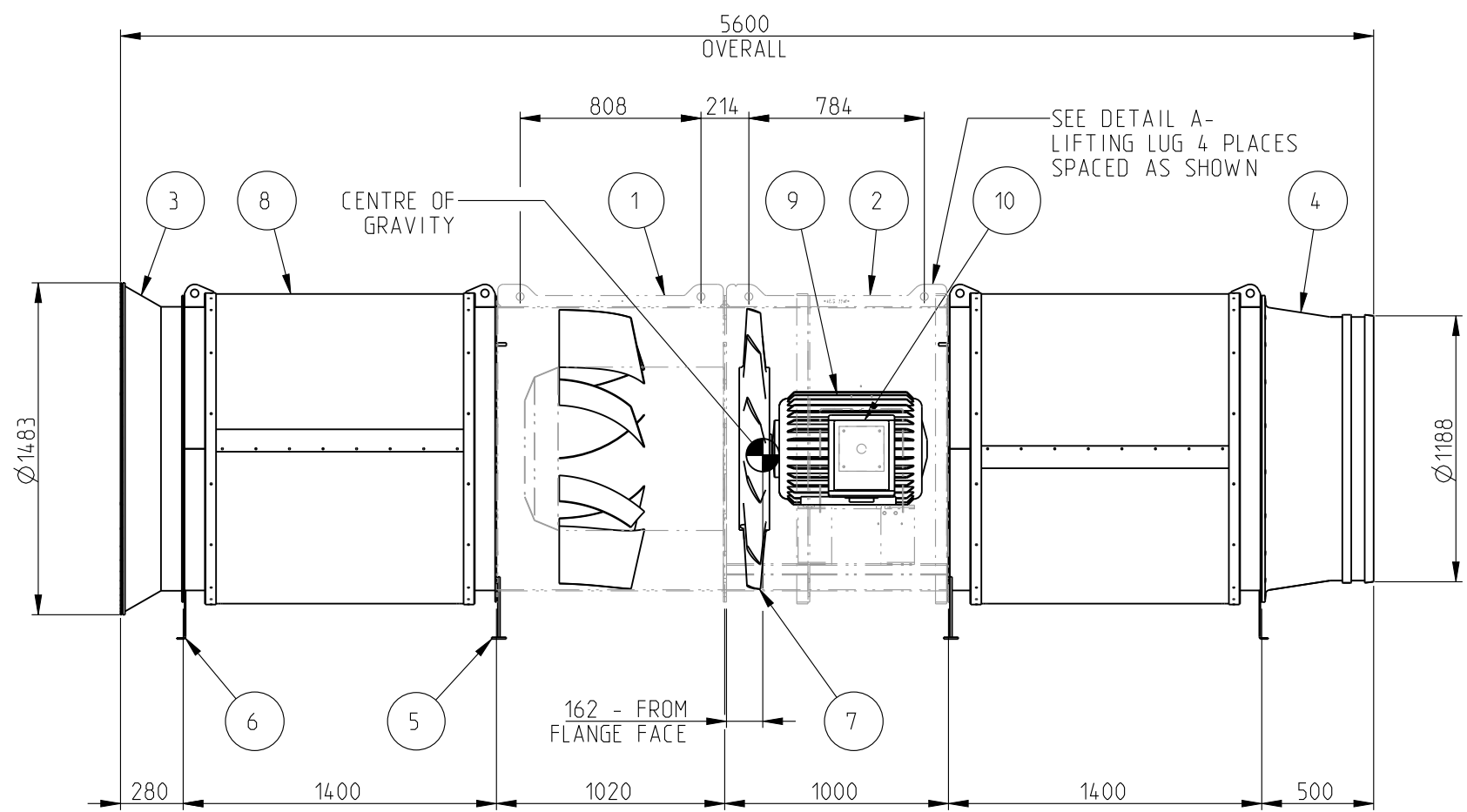

#### ASSEMBLY NOTES

- ALL MOTOR HOLD DOWN BOLTS, NUTS AND WASHERS TO COMPLY WITH AS1110 CLASS 8.8 ZINC PLATED. CONE LOCKING NUTS TO BE USED. ENSURE BOLTS ARE TIGHTENED TO CORRECT TORQUE
- ALL FLANGE BOLTS, NUTS AND WASHERS TO COMPLY WITH AS1111 CLASS 4.6 ZINC PLATED U.N.O

MASS: 1652.1 kg	SURFACE AREA: 99.92 m <sup>2</sup>	VOLUME: 0.790 m <sup>3</sup>	PROJECTION: 	COPYRIGHT		CLEM CORP (WA) Pty Ltd trading as <b>Clemcorp Australia</b> ABN: 54 115 959 683 PO Box 4249 Alexander Heights 6064 Western Australia Ph: (08) 9406 3000 Fax: (08) 9406 3001 www.clemcorp.com.au
MATERIAL: ■			TOLERANCE: U.N.O	This drawing including the principles of design is the property of and is submitted by CLEM CORP (WA) Pty Ltd with the agreement that it is not to be reproduced, copied or loaned in part or whole if it is not to be used in any manner that may constitute a detriment directly or indirectly to CLEM CORP (WA) Pty Ltd. Acceptance of this drawing will be construed as an agreement to the above.		
<b>ALL DIMENSIONS IN MM U.N.O          DRAFTING STANDARD AS1100          DO NOT SCALE</b>			X° ± 0.5° X ± 1 X.X ± 0.2 X.XX ± 0.02 >1000 mm ± 2	<b>CC1254 MK3 75kW 4P 1000V 1S OUT IC          2SIL VTA</b>		Drawing Number <b>1254-518</b>
16-08-21	SILENCERS REPLACED WITH NEW RIVETED SILENCERS	3	L PADGETT	Drawn	L PADGETT	31-12-20
DATE	DESCRIPTION	REV	BY	Checked	.	Scale
				Approved	.	NTS
				SHEET 1 OF 1		Rev. 3
				Design		

