

PARTS LIST

| ITEM | PART NO | REV | DESCRIPTION | QTY | MASS (ea) kg |
|------|--------------------------|-----|---|-----|--------------|
| 1 | 1254-001 | 5 | CC1254 GUIDE VANE- GV1 WELDED ASSY | 1 | 171.1 |
| 2 | 1254-010 | 1 | CC1254MK3- 24deg 70mm BORE 55KW- INLET IMPELLER MACHINING | 1 | 70.5 |
| 3 | 1254-014 | 7 | CC1254 MK3 AXIAL FAN CASING- 55kW INLET | 1 | 307.4 |
| 4 | 1254-026 | 1 | CC1254 INLET CONE | 1 | 52.8 |
| 5 | 1254-035 | 1 | CC1254 PLASTIC VENT TUBE ADAPTER TO 1220mm DUCT | 1 | 17.5 |
| 6 | 1254-044 | 3 | MOUNTING FOOT- CC1254 FAN- STD | 2 | 17.1 |
| 7 | 1254-052 | 3 | TRANSPORT FOOT- CC1254 SILENCER (STD & MIM SPEC) | 2 | 3.1 |
| 8 | 1254-146 | 3 | CC1254 AXIAL FAN SILENCER- RIVETED ASSEMBLY | 2 | 155.5 |
| 9 | EM-041 | 3 | TECO 55kW 4POLE 250SC FRAME 1000 VOLT MOTOR | 1 | 510.0 |
| 10 | MOTOR-TERM-BOX-TECO-D250 | 1 | TERMINAL BOX- SUIT TECO D250 FRAME | 1 | 26.0 |

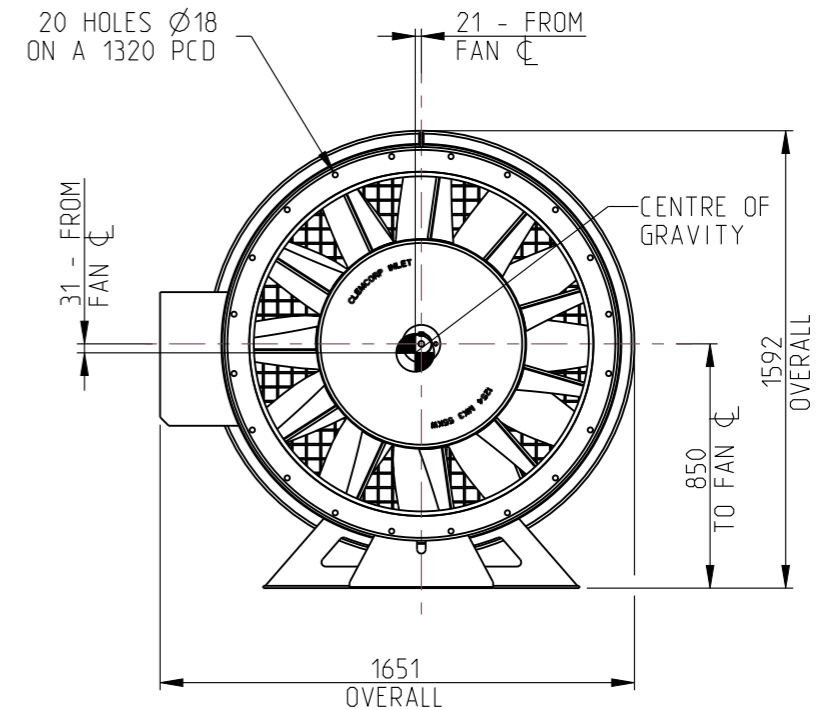
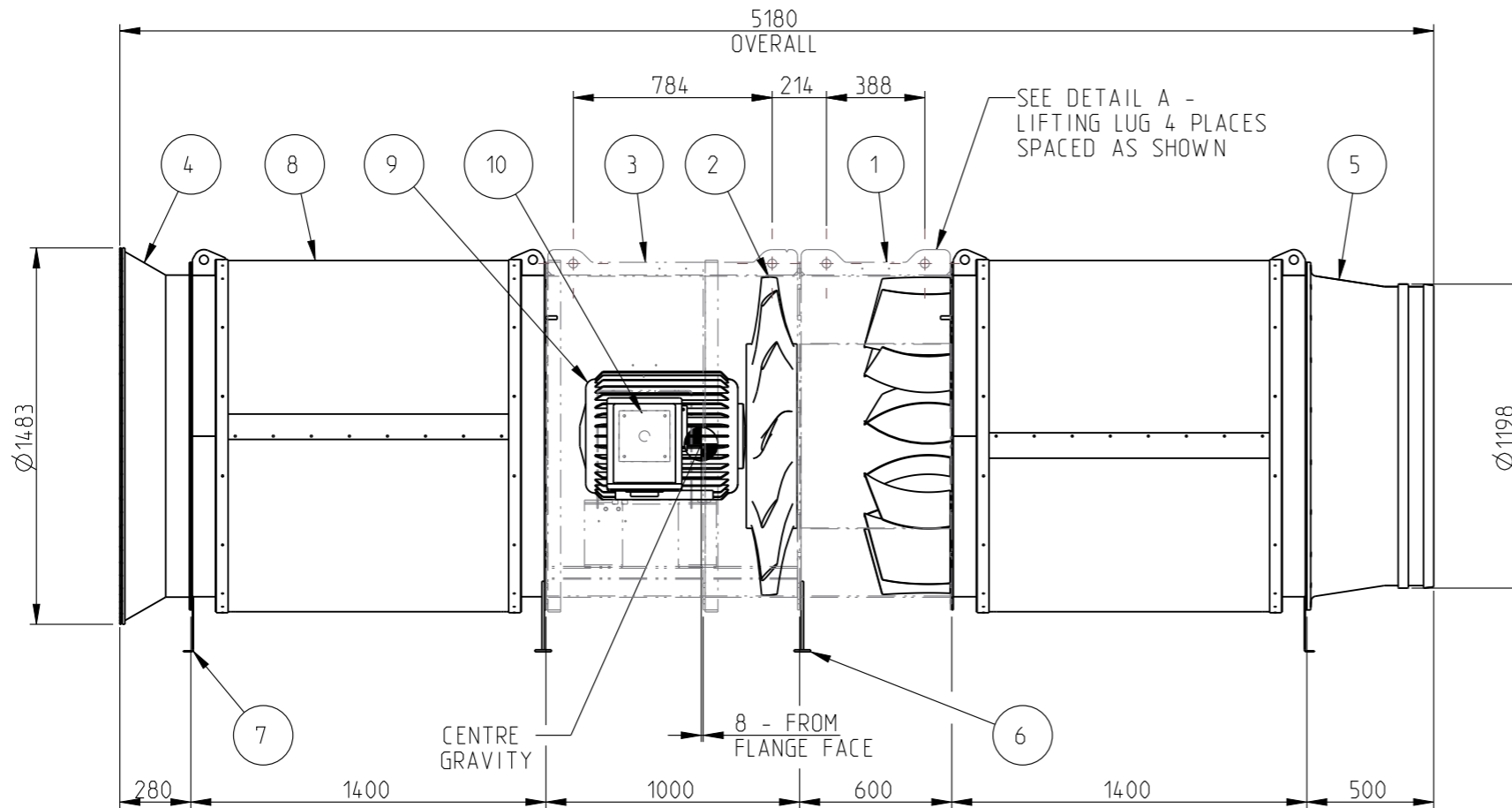
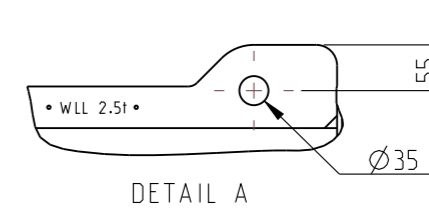

- NOTES
- ALL MOTOR HOLD DOWN BOLTS, NUTS AND WASHERS TO COMPLY WITH AS1110 CLASS 8.8 ZINC PLATED. CONE LOCKING NUTS TO BE USED. ENSURE BOLTS ARE TIGHTENED TO CORRECT TORQUE
 - ALL FLANGE BOLTS, NUTS AND WASHERS TO COMPLY WITH AS1111 CLASS 4.6 ZINC PLATED U.N.O

| | | | | | | |
|--------------------|--|---------------------------------|--|----------------|--|--|
| MASS: 1506.5 kg | SURFACE AREA: 312.38 m ² | VOLUME: 0.893 m ³ | PROJECTION: | COPYRIGHT | | CLEM CORP (WA) Pty Ltd trading as Clemcorp Australia ABN: 54 115 959 683 PO Box 4249 Alexander Heights 6064 Western Australia Ph: (08) 9406 3000 Fax: (08) 9406 3001 www.clemcorp.com.au |
| MATERIAL: - | | | ALL DIMENSIONS IN MM AT 20°C TEMP UNO DRAFTING STANDARD AS1100.101 & AS1100.201 DO NOT SCALE | | This drawing including the principles of design is the property of and is submitted by CLEM CORP (WA) Pty Ltd with the agreement that it is not to be reproduced, copied or loaned in part or whole if it is not to be used in any manner that may constitute a detriment directly or indirectly to CLEM CORP (WA) Pty Ltd. Acceptance of this drawing will be construed as an agreement to the above. | |
| 08-03-23 | DRAWING FORMAT UPDATED | 4 | L PADGETT | Drawn | L PADGETT | 08-03-23 |
| DATE | DESCRIPTION | REV | BY | Checked | . | Scale |
| | | | | Approved | . | NTS |
| | | | | Drawing Number | | Rev. |
| | | | | 1254-513 | | 4 |
| | | | | SHEET 1 OF 1 | | Design |

